



Safety and operation instruction

IB 260

Made in Italy

- SCARIFIER MANUAL -

CONTENTS

1.	USE OF THE MANUAL.....	<i>pag. 4</i>
2.	NOTICES ON THE MACHINE.....	<i>pag. 5</i>
3.	TECHNICAL DATA.....	<i>pag. 8</i>
4.	LIFTING AND TRANSPORTATION.....	<i>pag. 9</i>
5.	MAIN PARTS OF THE MACHINE.....	<i>pag. 9</i>
6.	CONTROLS AND ADJUSTMENTS.....	<i>pag. 10</i>
7.	ASSEMBLY INSTRUCTIONS FOR THE HANDLEBARS.....	<i>pag. 11</i>
8.	SAFETY INFORMATION	
	A) GENERAL INSTRUCTIONS.....	<i>pag. 12</i>
	B) TRAINING.....	<i>pag. 12</i>
	C) PREPARATION.....	<i>pag. 12</i>
	D) WORKING USE.....	<i>pag. 13</i>
	E) AFTER WORK.....	<i>pag. 14</i>
9.	TRANSPORTATION OF THE MACHINE.....	<i>pag. 14</i>
10.	SAFETY SYSTEMS AND GUARDS.....	<i>pag. 15</i>
11.	OPERATIONS TO BE CARRIED OUT BEFORE SWITCHING ON.....	<i>pag. 16</i>
12.	STARTING AND DRIVING THE SCARIFIER.....	<i>pag. 17</i>
13.	CUTTING TIPS.....	<i>pag. 18</i>
14.	CHECKS	
	A) CABLE CONTROL ADJUSTMENT.....	<i>pag. 19</i>
	B) BLADE ROTOR BELT ADJUSTMENT.....	<i>pag. 19</i>
	C) CHECKING AND REPLACING THE BLADES.....	<i>pag. 20</i>
	D) ROTOR BRAKE.....	<i>pag. 21</i>
15.	MAINTENANCE AND STORAGE.....	<i>pag. 22</i>
16.	CLEANING THE MACHINE.....	<i>pag. 22</i>
17.	SEASONAL LONG-TERM STORAGE PERIODS.....	<i>pag. 23</i>
18.	DECOMMISSIONING AND SCRAPPING.....	<i>pag. 23</i>
19.	TECHNICAL ASSISTANCE.....	<i>pag. 23</i>
20.	WARRANTY.....	<i>pag. 24</i>
21.	CE MARKING.....	<i>pag. 24</i>

Enclosure 1. NOTES

Enclosure 2. Declaration of Conformity

Operating and Safety Instruction

SCARIFIER MOD. IB 260

FOREWORD

This machine may only be utilized for the purpose for which it was designed, i.e. agricultural use, for the cutting of shoots, grass and brushwood.

Any other use other than that stated, not covered or deducible from this Manual and the enclosed Engine Manual is "PROHIBITED".

Failure to comply with instructions in this Manual and in the Engine Manual releases the manufacturer from all liability, in particular for any damage resulting from improper or incorrect use, through negligence, superficial interpretation or flagrant disregard for the safety requirements herein.

Get your dealer to explain how to use the machine in optimum safety conditions.

Always perform the checks as prescribed herein before each work session with the machine.

Should any information given in the following pages be unclear or not straightforward please contact the manufacturer directly.

1. USE OF THE MANUAL

This Manual consists of numbered pages and enclosures featured in the list of contents. Before operating the machine the user must read the instructions in the Operator's Manual carefully as well as those of the Engine Manual enclosed.

Use of the flail mower by more than one operator (individually), means that they must have carefully read the Operator's Manual and the Engine Manual before using it.

The aforementioned manuals form an integral part of the machine and must therefore be kept intact and in good condition, in a known, easily accessible place for the entire working life of the machine, even if the flail mower is passed on to another owner. The purpose of these manuals is to provide the information necessary for the safe and competent use of the product. In the instance of wear or purely for a greater technical working knowledge, the manufacturer may be contacted directly. The Notes Section at the end of the Flail mower Manual is for the addition of any complementary notes.

In this Manual all safety information appears in special boxes headed **⚠WARNING⚠**

WARNING

This heading is used to draw the user's attention to hazardous areas or moving parts of the machine. It is also used in instances where failure to comply with the instructions given may result in injury to persons and animals or damage to property.

2. NOTICES ON THE MACHINE

The symbols affixed to the machine serving to warn of danger during its use and maintenance are as follows:

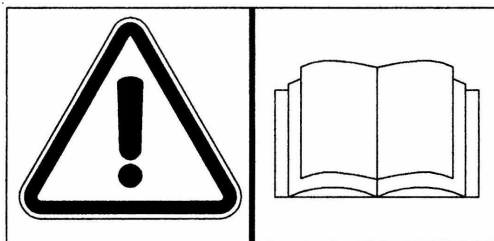

THE USER MUST READ THE INSTRUCTION MANUAL PROVIDED

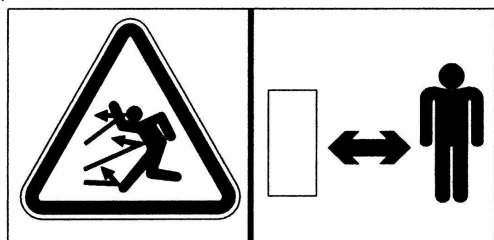

DANGER OF FOREIGN OBJECTS BEING THROWN OUTWARDS. KEEP A SAFE DISTANCE

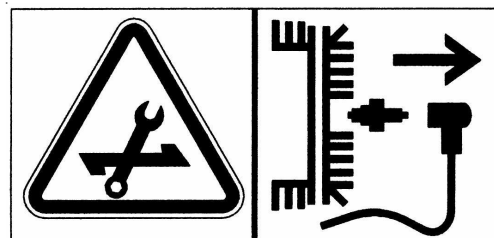

ALWAYS DISCONNECT THE CABLE FROM THE ENGINE SPARK PLUG.

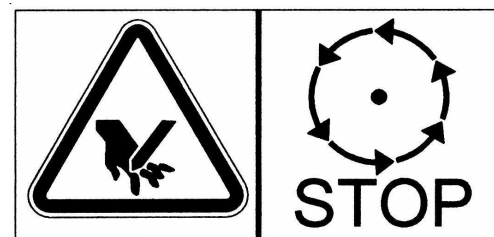

DANGER OF HAND INJURY. SWITCH OFF THE ENGINE

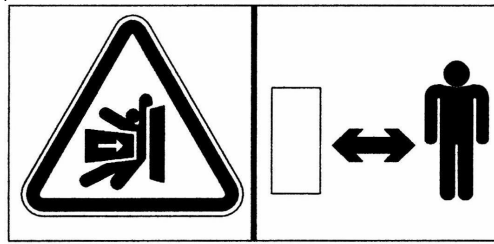

DANGER OF CRUSHING. KEEP A SAFE DISTANCE



DANGER OF INJURY TO BOTH UPPER AND LOWER LIMBS.
DO NOT PUT HANDS OR FEET INSIDE THE CUTTING
ELEMENT WHILE IN MOTION

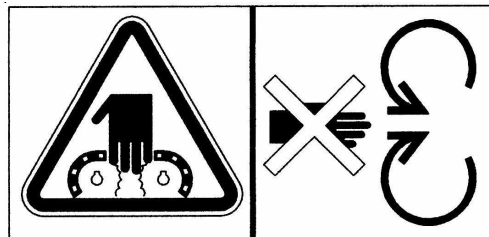

DANGER OF GETTING CAUGHT UP IN ROTATING PARTS.
DO NOT PUT HANDS IN THE ROTATING PARTS

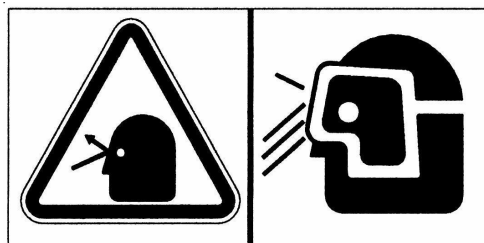

DANGER OF FOREIGN OBJECTS BEING THROWN OUTWARDS.
SAFETY GOGGLES MUST BE WORN

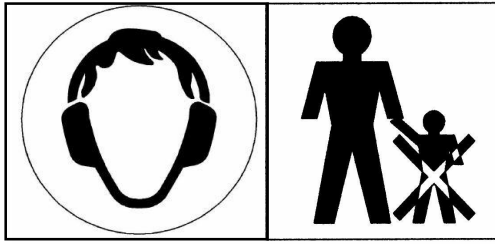

EAR DO NOT ALLOW CHILDREN NEAR THE MACHINE
WHEN IN OPERATION.MUFFS MUST BE WORN

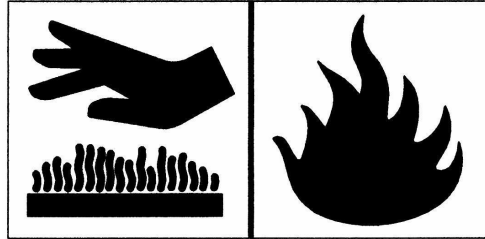

CAUTION: HOT PARTS. DANGER OF BURNS. FIRE HAZARD

The symbols affixed to the machine serve to warn of danger during its use and maintenance. It is vitally important to understand the meaning of the danger notices and all messages should be kept in legible condition. In the instance of wear these notices should be replaced and use of the machine suspended while without such notices. The operator is advised to observe the warnings given on the affixed notices. Consult this page whenever doubts about their meaning arise.

3. TECHNICAL DATA OF THE MODEL IB 260

ENGINE:	petrol
ENGINE CAPACITY:	3.6 kW
WORKING WIDTH:	50 cm
CUTTING HEIGHT:	adjustable 0 - 25 mm
CUTTING SYSTEM:	48-blade rotor
MOVEMENT:	hand-pushed
WHEEL RELEASE MECHANISM:	mechanical
START:	recoil
HANDLEBARS:	height-adjustable
WHEELS:	in rubber, rear Ø 250, front Ø 200
SIZE L x W x H (mm):	1420 x 700 x 980
WEIGHT (kg):	74

ACOUSTIC PRESSURE, measured according to EN 12733 :	89 dBA
ACOUSTIC POWER, measured according to EN 12733 :	LWA 98 dBA
HANDLEBAR VIBRATION (EN 12 733) AW :	5.1 m/s ²

Environmental conditions

Unless otherwise stated at the time of ordering it is understood that the machine is to work normally in the environmental conditions covered by the following points.

Environmental conditions other than those described may cause mechanical breakage resulting in the creation of dangerous situations for persons.

ALTITUDE

The altitude of the place in which the machine is to be used must not exceed 1500 m above sea level.

TEMPERATURE

Minimum ambient temperature: -5°C

Maximum ambient temperature: +50°C

ATMOSPHERIC CONDITIONS

The electrical equipment will function correctly in atmospheric conditions with a relative humidity up to 50% at a temperature of 40°C and at 90% with a temperature up to 20°C (without condensate).

ATMOSPHERE WITH RISK OF EXPLOSION AND/OR FIRE

The standard machine herein described is not designed to work in explosive atmospheres or in those with risk of fire.

4. LIFTING AND TRANSPORTATION

All material is carefully checked by the manufacturer before shipping. The scarifier is delivered in a wooden crate or cardboard box with the handlebars disassembled.

Upon receipt of the machine make sure that it has not been damaged during transit and that the packaging has not been tampered or any parts removed. Report any damage or missing parts immediately to the carrier and the manufacturer with photographic documentation.

After assembling the handlebars, as per the instructions given in paragraph 7 of this manual, the machine may be moved on its own wheels.

The manufacturer is not liable for any damage caused by transportation of the machine after its delivery.

WARNING

Extreme care must be taken during handling to prevent overturning. Avoid steep gradients to prevent loss of control. Make sure that there are no persons present within the danger area.

5. MAIN PARTS OF THE MACHINE

The machine consists of the following main parts:

- A - BLADE ENGAGEMENT CLUTCH LEVER
- B - ACCELERATOR CONTROL LEVER
- C/C1 - CUTTING HEIGHT ADJUSTMENT LEVER
- D - ENGINE
- E - FRONT GUARD

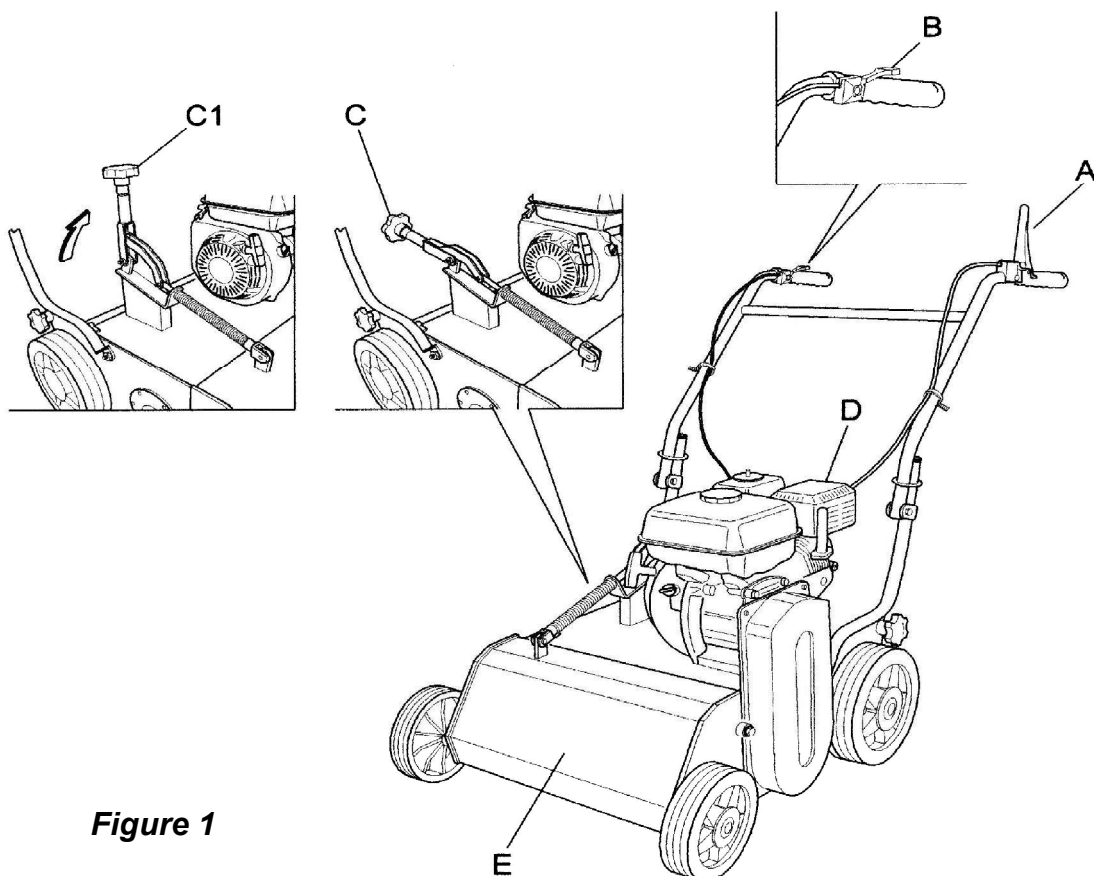

Figure 1

6. CONTROLS AND ADJUSTMENTS

A) BLADE ENGAGEMENT CLUTCH LEVER

This is used to engage and disengage rotary movement of the blade holder rotor. Lowering the lever engages the clutch and releasing it disengages the clutch.

B) ACCELERATOR CONTROL LEVER

This is used to adjust the number of engine revolutions according to the operations to be carried out. Hence at switch on the lever will be positioned on the minimum setting whilst during work operations it will be positioned as required by use.

C)) CUTTING HEIGHT ADJUSTMENT LEVER

The lever has two positions. In position C1 it raises the front guard to which the wheels are fixed, permitting the operator to shift the scarifier without the blades touching the ground.

In position C it permits millimetric adjustment of blade cutting height by turning the knob (Fig. 1 Ref. C1) clockwise or anticlockwise.

E) FRONT GUARD

The front guard to which the wheels are fixed determines use of the scarifier on the basis of the position selected (See point C) with the cutting height adjustment lever.

H) FRONT GUARD

The front guard (Fig. 1 Ref. H) opens or closes automatically according to the amount of grass to be cut. Use of the machine with the guard left open is strictly prohibited. This may cause the outward projection of objects.

The guard may only be set in the open position during flail replacement operations with the machine switched off.

I) ON SWITCH

Two-position switch:

(1) for starting the engine

(0) for switching off the engine

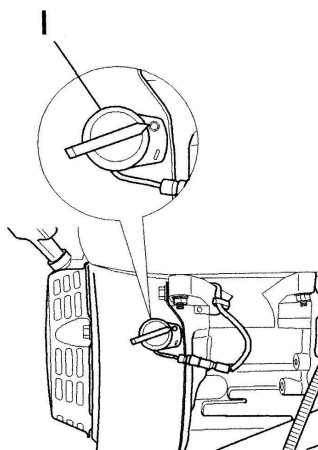

Figure 1 bis

7. ASSEMBLY INSTRUCTIONS FOR THE HANDLEBARS

The scarifier is delivered with the handlebar disassembled (Fig.2 ref A). Remove the crating or cardboard packaging (this should be disposed of properly, in compliance with current regulations in force).

To assemble, proceed as follows:

- Raise the handlebar (Fig. 2 ref. A) and fit it into the support (Fig. 2 ref. F) by securing it using the special rings (Fig. 2 ref. E).
- Fit the screws (Fig 2 ref. B) in the hole in the handlebar support (Fig 2 ref. F). Position the washers (Fig. 2 ref. C) on the relative screws (Fig. 2, ref. B) and tighten the nuts (Fig. 2 ref.D) firmly.

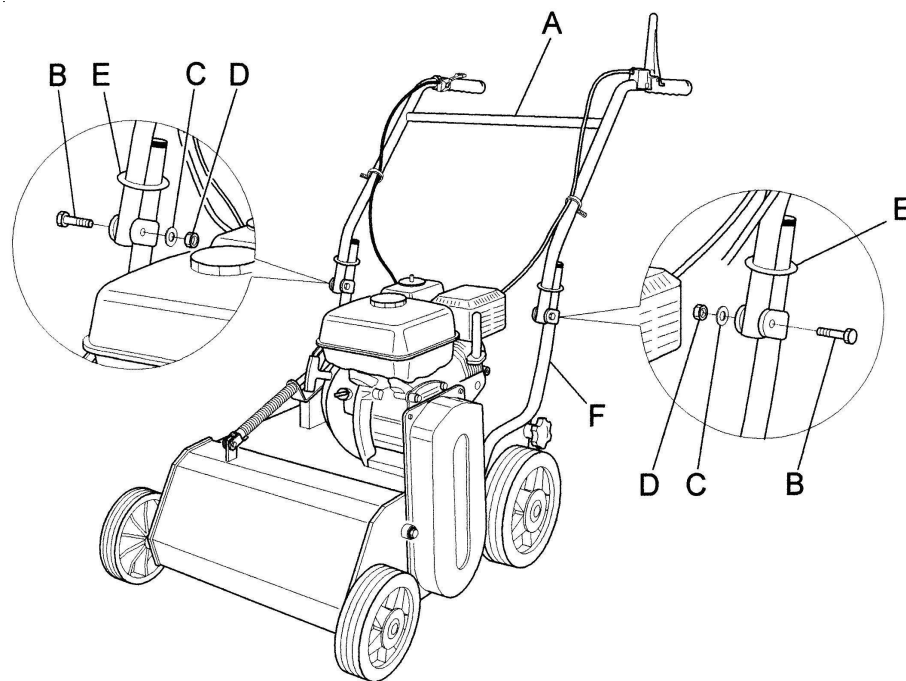

Figure 2

Before start-up all parts of the machine must be correctly assembled.

8. SAFETY INFORMATION

Before using the scarifier it is essential that the operator has understood the warnings, do's and don'ts and precautionary measures given in this manual and in the engine manual: the prevention of injury to the operator, third parties, animals or objects directly depends on observance of these instructions.

A) GENERAL INSTRUCTIONS

- Use of the scarifier for purposes other than those envisaged is strictly prohibited.
- Climbing aboard and/or riding on the scarifier is strictly prohibited.
- Tampering with the safety systems and guards is strictly prohibited.
- Modifications to devices/components not envisaged by the manufacturer are strictly prohibited.
- The electrical parts of the engine must be protected at all times.

B) TRAINING

- Read the Operator's Manual and the Engine Manual before using the machine.
- Use of the machine by minors under the age of 16 years or by persons without the necessary psychological and physical capabilities is forbidden.
- Do not use the machine near other persons or within enclosed areas.
- The placing of hands, other parts of the body and clothing in the moving parts of the machine is prohibited.
- It is forbidden to approach the moving parts.
- Before carrying out any inspection or servicing operations make sure that the engine has been switched off and the spark plug wire removed.

C) PREPARATION

- Make sure that the working area around the machine is free of obstacles and has sufficient lighting.
- Before switching on the engine make sure there are no persons, animals or vehicles in the vicinity.
- Before switching on the engine make sure that the blade engagement lever (Fig. 1, ref. A) is in the disengaged position (released) .
- Before switching on the machine make sure that the screws, fixing elements and protection devices are in place and that the affixed notices are legible.
- Then: Make sure that the wheel fixing bolts have been tightened fully.
- Secure all blade nuts and fixing bolts (Fig.9, ref. A) to prevent their loss during work operations. Replace any old or worn blades.
- The rear guard must always be closed while the machine is in use or open only if the scarifier is equipped with the special basket (Fig. 3,ref.A and Fig. 4, ref.B).
- When switching on the engine check the position of the various control levers (see the section on "Controls and adjustments").
- Supervise the clothing of personnel operating the machine: a long-sleeved jacket with close-fitting cuffs, long, close-fitting trousers, heavy-duty footwear, and a protective cap or helmet should be worn. Avoid wearing loose-tailed clothing, unbuttoned jackets or torn, undone or partially zipped up items to prevent them from being caught up in the moving parts.
- Safety goggles and ear protection devices must be worn. Safety gloves must also be worn during machine operation and maintenance.
- Do not switch on and operate the scarifier in enclosed areas since the engine gives off carbon monoxide fumes which are colourless, odourless, tasteless and extremely dangerous.

- Take care when handling fuel. Fuel is highly flammable and its vapours explosive :
 - Only use an approved container
 - Take care not to remove fuel caps or top up the tank with the engine running.
 - Allow the engine to cool before proceeding with fuel-filling operations.
 - Do not smoke during this operation.
 - Never fill the machine with fuel in an indoor ambient
 - It is advisable to use a wide funnel to prevent spillage of fuel on the engine and on other surfaces of the scarifier
 - If any fuel is spilled do not attempt to switch on the engine; simply move the machine away from the area of spillage before switching on.
 - After filling up with fuel reposition and screw the fuel tank cap right down.
- Do not rest the scarifier or the fuel container in indoor environments with naked flames

D) WORKING USE

- When working keep everyone at a minimum distance of 10 metres from the machine.
- Keep the engine well ventilated and clog-free (materials and other residue) to prevent damage to the engine and risk of fire. **Clean the cooling fan and fins regularly.** Clean the air filter at the same time as well.
- Drive smoothly, avoiding brusque starts, braking and turns.
- Take care not to touch the silencer when hot.
- When reversing make sure there are no children or animals around. Take care not to get caught up in the moving parts of the machine.
- If a slipping belt causes abnormal noise, smells or overheating, switch off the engine immediately and check the machine to prevent the outbreak of fire and damage to the transmission.
- The rotating blades are extremely dangerous. Keep away from the rotor guard when the blades are in motion. do not allow anyone to stand either in front of the machine or in its direction of travel.
- When working in a stony or obstacle-riddled area try to remove as many objects as possible before commencing cutting.

WARNING

Stones and other objects may be thrown outwards in direction of the operator or of other persons in the vicinity. Keep at a safe distance from persons, animals and objects.

- If the cutting mechanism accidentally comes into contact with an object (stump or stone), switch off the engine and carry out the following operations:
 - Inspect the damage
 - Do not attempt to repair it if unskilled to do so
 - Check that no parts have come loose
- Do not use the machine if it does not work properly or is broken: seek authorized service.
- It is strictly prohibited to leave the scarifier running whilst unsupervised.
- It is strictly prohibited to transport the machine with the engine running. When loading the machine onto a vehicle, the inclination of the ramps must not exceed 15°.

WARNING

EXERCISE CAUTION WITH GRADIENTS . Danger of machine overturning.

- Given its outdoor use, it is advisable not to use the scarifier when it is raining.
- The area next to the engine exhaust may reach a high temperature.

WARNING

Danger of burns.

- Do not go near water fountains or precipices and do not cross narrow bridges during work operations to prevent the risk of falling.
- Do not work on steep banks with gradients in excess of 10°.
- Work on flat ground for the utmost safety.

E) AFTER USE

- Before moving away from the machine switch off the engine by moving the switch (Fig.1,ref.I) to the 0 position.
- For greater safety shut off the feed cock (Fig. 5a).

9. TRANSPORTATION OF THE MACHINE

LOADING AND UNLOADING FROM A VEHICLE

- For transportation it is preferable to use a vehicle with an open bed.
- Choose firm, flat ground.
- Switch off the vehicle's ignition, pull on the hand brake and block the tyres with chocks to prevent accidental movement of the vehicle.
- Do not stand in front of the machine
- Firmly hook the loading ramps onto the vehicle bed. Use stable load ramps with a non-slip surface strong enough to take the weight of the machine. The inclination of the ramps must not exceed 15°.
Recommended length : at least 3¹/₂ times the vehicle bed's height from the ground.
Recommended width : to be chosen according to the wheel width of the machine
- Proceed with the loading of the machine, manoeuvring it carefully.
- During loading and unloading on the ramps, avoid activating the blade engagement clutch.
- Align the machine's front skid with the centre of the loading ramps.
- Take care when the machine passes from the loading ramps to the vehicle bed, because a shift in balance occurs.
- Once loaded, block the machine wheels using chocks and firmly tie the machine to the vehicle.

10. SAFETY AND GUARD SYSTEMS

WARNING

The safety devices must never be tampered with. It is necessary to understand how they work and safeguard their efficiency and correct operation. In the instance of doubt, problems or malfunction contact your dealer.

BLADE ROTOR ENGAGEMENT LEVER

When released this lever instantly disengage the transmission connected to it. In this way it acts as a safety device.

FRONT GUARD

Use of the machine with the front guard incorrectly fitted or damaged is strictly prohibited. This may cause the outward projection of objects.

REAR GUARD

Use of the machine with the rear guard left open or tampered is strictly prohibited. This may cause the outward projection of objects.

Use of the rear guard open (Fig. 3 Ref. A) is permissible only when the collection basket is inserted in the special housing.(Fig.4, ref.B)

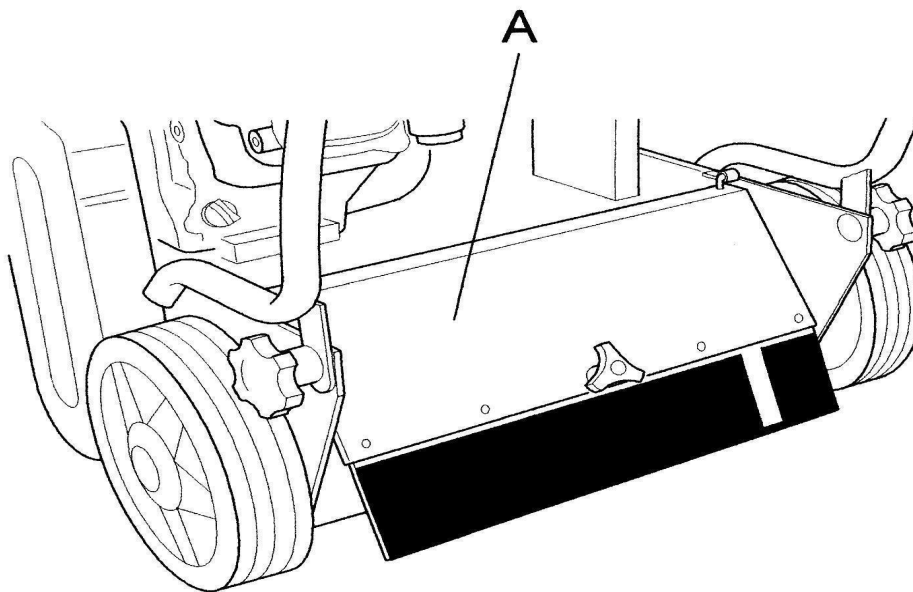

Figure 3

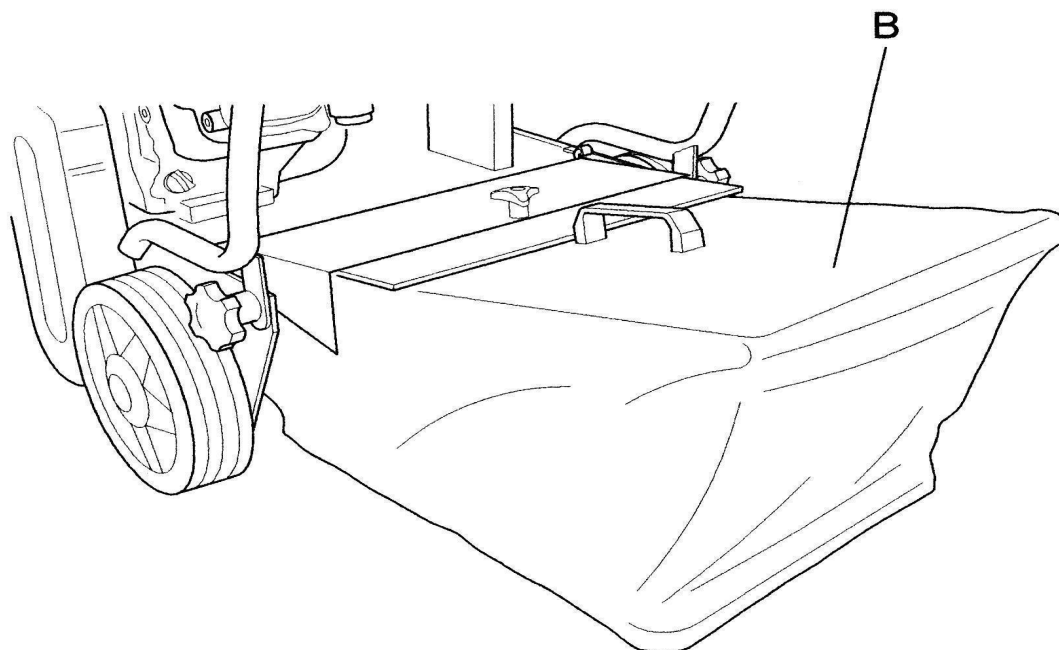

Figure 4

11. OPERATIONS TO BE CARRIED OUT BEFORE SWITCHING ON

Position the scarifier outdoors on sufficiently firm, flat soil. Read the instructions provided by the engine manufacturer in the relative manual and follow them carefully to prevent situations arising which may endanger either persons or the machine.

Then check:

- the state of the blades by inspecting them;
- that all the screws are tightened, particularly those securing the blades;
- that the guards and safety devices are securely tightened;
- take sure that there are no persons in the vicinity;

During operation do not allow persons near the machine, especially children. The operator is responsible for any harm done persons in the working area of the machine.

Oil recommendations

Before switching on the engine check the oil level and top up, if necessary, while keeping it in a horizontal position. Do not overfill.

Use of a high-grade detergent oil is recommended (refer to the enclosed engine manual).

Fuel recommendations

Use of fresh, clean lead-free petrol is advised.

WARNING

It is advisable to consult the engine manual before swithcing on the machine.

12. STARTING AND DRIVING THE SCARIFIER

The machine can be switched on once all the aforementioned preliminary operations have been carried out.

- Place the feed cock in the OPEN position (direction shown by the arrow, Fig. 5);
- Bring the choke to the CLOSED position for a cold start (direction shown by the arrow, Fig. 5a);
- Set the accelerator lever at the minimum position;
- Grip the engine pull lead handle (fig. 5b) and pull gently until you feel the "bite", then pull on the lead sharply to overcome the pressure, prevent kickback and switch on the engine. Repeat the procedure, if necessary, with the accelerator lever in INTERMEDIATE position. Once the engine is running, set the accelerator lever in the MINIMUM position and gently return the choke to the OPEN position (Fig. 5a);

Cleaning of the machine is recommended after use (see the section "Cleaning the machine").

Figure 5

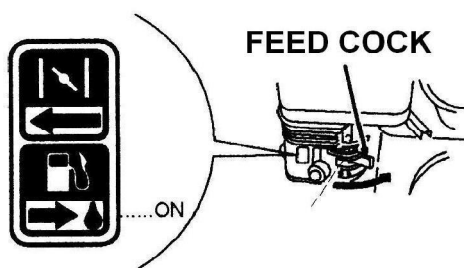

Figure 5a

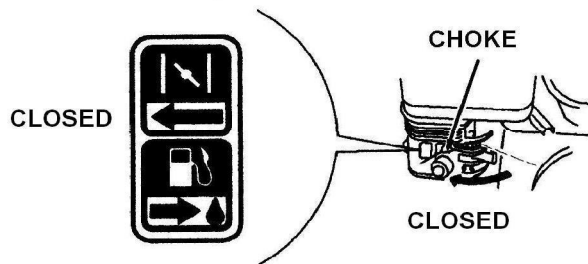
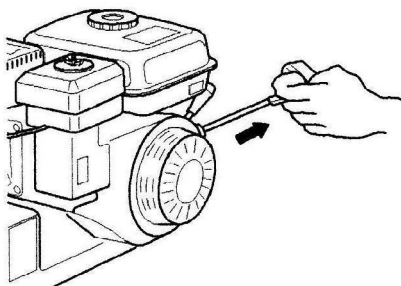

Figure 5b



DRIVING THE MACHINE

WARNING

When using the machine for the first time it is advisable to get the feel of it by executing manoeuvres on flat ground free of foreign objects. Cut in a straight line .

After switching on the engine following the instructions given in the previous paragraph:

1. Engage the blade rotor clutch control using the special lever (Fig. 1, ref. A) after accelerating the engine slightly.
2. To move the machine push it in the direction required.
3. To stop blade movement release the lever in question (Fig. 1 ref. A);
4. To stop the machine, gradually slow down forward movement, then switch off the engine by moving the switch to position 0 (as shown in fig. 1bis, ref. I).
5. To move the machine with the engine switched off set the cutting height adjustment lever (Fig. 1 ref. C-C1) to position C1 and push in the required direction.

13. CUTTING TIPS

1. Before commencing cutting operations, read the safety instructions given in the previous sections.
2. Before engaging blade movement using the relative lever (figure 1, ref. A) the rear guard (fig. 3, ref. A) must be fully lowered or the special basket must be inserted (fig. 4, ref.B) to prevent the outward projection of objects.
3. Engage the blade clutch (Fig. 1, ref. A) only after having carried out the machine switch-on (see “ SWITCHING ON” section)
4. Engage the blade clutch (Fig. 1, ref. A) gradually. Overly brusque blade clutch engagement may stall the engine.

WARNING

Take great care because the blades rotate at very high speed.

14. CHECKS

- Adjust the belt and cable control tension after the first few working hours to compensate initial loosening.
- Briefly operate all the machine's components to detect any abnormal noises or overheating.
- During the initial running in period avoid heavy-duty usage to encourage proper settling of the mechanical parts.
- Never neglect maintenance operations after work and carry out all prescribed checks regularly.

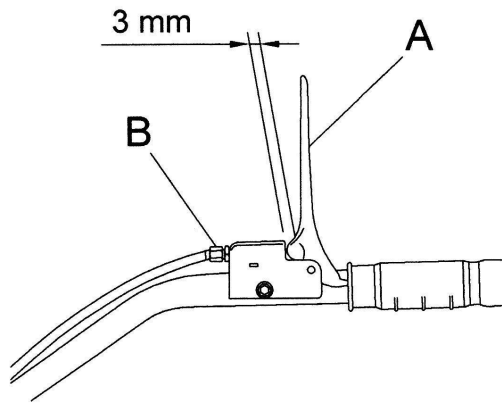

Figure 6

A) BLADE HOLDER ROTOR CONTROL CABLE (Fig. 6)

To adjust the cables place the machine on flat ground, switch off the engine and disconnect the wire from the spark plug.

For correct machine functioning there must be a play of approx. 2-3 mm on the blade holder rotor control lever. If there is no play, it must be taken up by turning the special adjustment screw clockwise or anticlockwise (Fig. 6, Ref. B).

If adjustment using the relative screw proves ineffective, the belts must be adjusted. To perform this operation refer to section 14 B “BLADE ROTOR BELTS” of this manual.

B) BLADE ROTOR BELTS

To adjust the belts place the machine on flat ground, switch off the engine and disconnect the wire from the spark plug.

- Take off the protective plastic film (Fig. 7 ref.B) by unscrewing and removing the fixing screws using the key as shown in fig. 7 ref. A.
- If the belts (Fig. 8 ref. A) are slack and fail to draw the pulley connected to the blade rotor (Fig. 8 ref. E) , move the tightener (Fig. 8, ref. D) from the lower hole (hole C) to the upper hole (hole B) as shown in Fig. 8.
- If adjustment using the relative screw proves ineffective, both belts must be replaced.

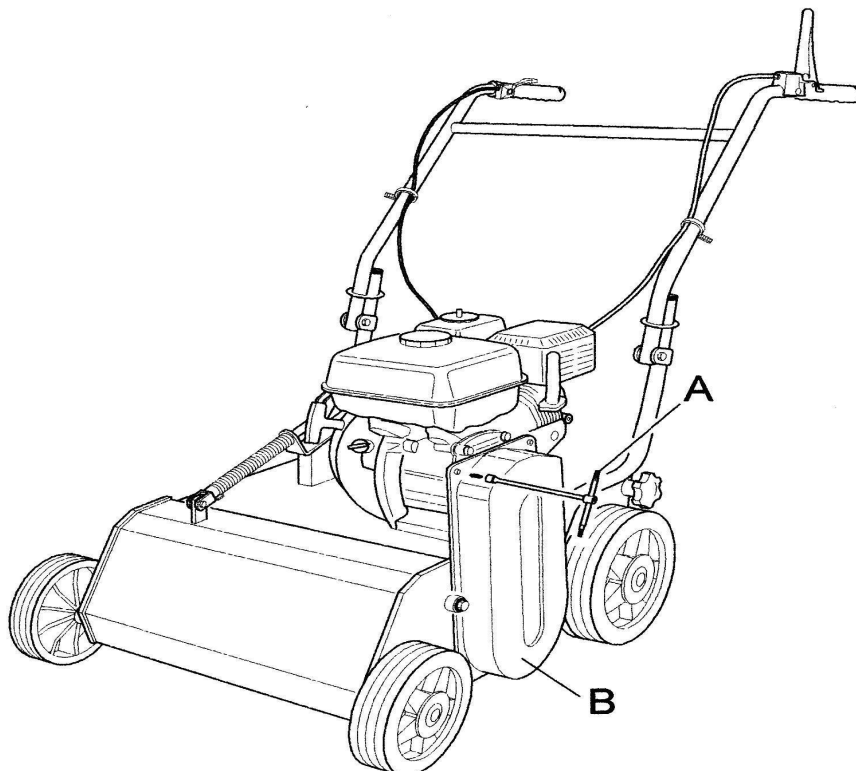

Figure 7

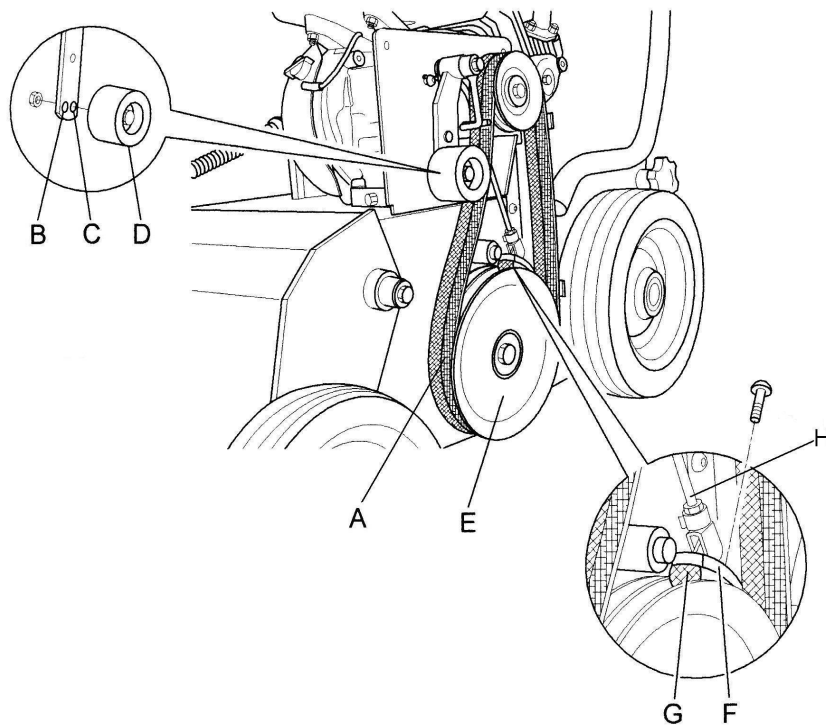

Figure 8

C) CHECKING AND REPLACING THE BLADES

Always check the state of the blades before commencing work. Do not forget to switch the engine off!

- During work operations if the blades (Fig. 9, ref. C) strike stones or stumps stop straightaway and make sure that they have not become bent or broken. Damaged blades must be replaced.
- If the blades are very worn, cracked or bent, they may snap and project objects outwards, risking serious accident.
- It requires specific experience and suitable equipment to replace and repair blades.
- Use heavy-duty work gloves to check or replace the blades to avoid risk of injury to hands.
- As a rule – unless there are only 1 or 2 blades – all the blades must be replaced simultaneously to avoid creating vibrations.
- The blades wear more quickly on dry, sandy ground. In these conditions they should be replaced more frequently.
- It is advisable to keep spare blades handy.

To remove the blades proceed as follows:

1. Switch off the engine and disconnect the spark plug wire.
2. Open the rear housing (Fig. 3 ref. A).
3. Check the condition of the blades (Fig 9 ref. C).
4. Make sure that there are no cracked, bent, worn or broken blades. Replace any damaged blades.
5. Unscrew the screw (Fig. 9 ref. A).
6. Remove the blade pin (Fig.9 ref. B).
7. Replace the blades, making sure that when the new ones are fitted the special spacers are fitted on again as well.

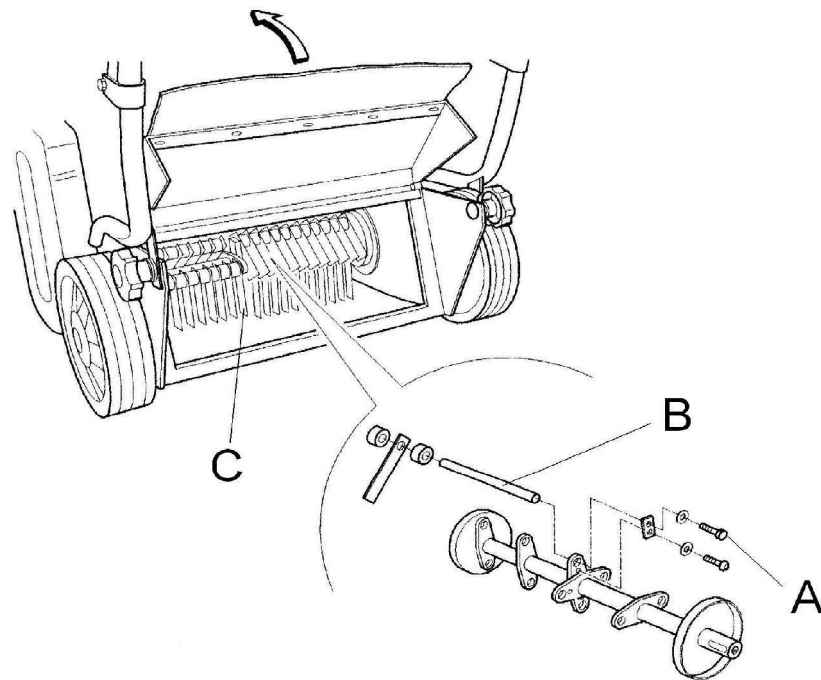

Figure 9

D) ROTOR BRAKE

The rotor brake (Fig. 8 Ref. F) is connected to the blade holder rotor control cable (Fig. 6 Ref. B). Operating the lever (Fig. 6 Ref. A) automatically disengages the brake. Releasing the lever engages the brake and locks the rotor.

In the instance of incorrect function either screw or unscrew the tie-rod (Fig.8 Ref. H) and check the condition of the braking element (Fig. 8 Ref. G), replacing it if necessary.

15. MAINTENANCE AND STORAGE

- All operations on the machine must be carried out exclusively by authorized personnel.
- Always switch off the engine when checking, adjusting or servicing the machine.
- Allow the machine to cool down before inspection.
- The belt guard (Fig. 7 ref. B) , the front guard (Fig. 1, ref. E) and the rear guard (Fig. 1,ref.A) must always be correctly installed and intact. If they become damaged, have them repaired before the machine is used again.
- Make sure that all the guards of rotating and moving parts are in place.
- For greater safety, when replacing the blades replace all the fixing screws and nuts at the same time, as described in section 14, point C.
- Inspect the fuel lines. These should be replaced if damaged or after a maximum of three years, along with the fixing bands. Old lines may leak fuel.
- Check and regularly adjust the blade rotor clutch and the accelerator.
- Cover the machine with a sheet after the engine and silencer have cooled down.
- It is strictly forbidden to place/leave unattended on the scarifier any potentially dangerous objects which may put the safety of persons or the machine at risk.
- Keep the machine in a good, clean state; do not leave it outside exposed to inclement weather conditions.
- After use store the machine in a place where children have no access. Always allow the machine to cool down before putting it away.
- After use store the machine in a place where fuel vapours cannot reach a naked flame or sparks.
- In the instance of a long period of non-use, drain the fuel tank completely.

Use of the machine does not require specific lighting.

However, the recommended minimum amount of light (e.g. 200 lux) is enough to be able to read the notices on the machine and to operate it without running risks caused by poor light.

16. CLEANING THE MACHINE

Proceed in the following order:

- Switch off the engine and disconnect the spark plug wire;
- Clean the engine and the outside of the machine with a cloth soaked in a little oil.
- Clean all parts of the machine, particularly the starting unit, air filter, exhaust and carburetor. It is advisable to follow the instructions given in the engine manual.
- Clean the inside of the belt guard (fig. 7, ref. B) with a blast of compressed air.
- To clean the inside of the front guard (fig. 1 ref. E) and of the rear guard (Fig. 1, ref. A) wash with a jet of water straight after use while still damp.
- When washing carefully cover and protect the electrical parts of the engine, the carburetor, the air filter and the exhaust from the water to prevent engine problems.
- To clean the blade area a tool should be used (stick of wood).

17. SEASONAL LONG-TERM STORAGE PERIODS

To store the scarifier for prolonged periods of non-use, proceed as follows:

- Park the machine on flat, firm, clean ground.
- Disconnect the spark plug wire;
- Clean the machine carefully as described in section "Cleaning the machine"
- Make sure that all screws and nuts are fully tightened.
- Retouch with paint any parts which have become exposed during use.
- Store the machine in a clean, dry place.
- Empty the fuel tank, following the instructions given in the engine manual;
- Lubricate all moving parts and have any necessary repairs to the machine carried out.

18. DECOMMISSIONING AND SCRAPPING

After the working life of the scarifier the user must have it dismantled and its components removed as per EEC directives or in accordance with current legislation in force in his country, taking particular care over the dismantling of the following materials of environmental impact:

- plastic parts
- rubber parts
- coated electric wiring
- petrol engine
- metal parts
- toxic substances

19. TECHNICAL ASSISTANCE

Routine maintenance must be carried out as per the instructions given in this Manual. For any instances not covered herein and for technical assistance in general contact your dealer referring to the data given on the identification plate affixed to the machine.

The right reference will ensure swift, precise answers.

For swift delivery of spare parts always quote the following information on the order:

- Machine model and serial number
- Part description and quantity required

For assistance concerning the engine it is advisable to contact the service centre authorized by the engine manufacturer (see engine manual supplied).

20. WARRANTY

The scarifier has a 12-month warranty which starts from the day of purchase, (or up to 50 hours' service, if for individual use) or 6 months (or up to 50 hours' service, if for commercial use) excluding the engine, for which the warranty supplied by its manufacturer applies.

The manufacturer will replace free of charge any parts it acknowledges to be faulty. Labour and transportation costs are to be paid by the customer.

For any problems or repair enquiries please contact your dealer. Warranty applications must be forwarded to the manufacturer via the dealer.

Any damage during transit must be reported to the dealer immediately.

As regards any materials not manufactured by us, particularly the engine, the regulations of the respective manufacturers apply. So, any applications for repairs must be forwarded to the specific service centres within those specific areas.

If maintenance work carried out on the machine does not conform to the instructions provided, involving the use of non-original spare parts or without the written authorization of the manufacturer, thus jeopardizing the integrity of the machine or changing its characteristics, the manufacturer will not be liable for the safety of persons or for the faulty operation of the machine.

All unauthorized modifications to the machine invalidate the warranty agreement.

21. CE MARKING

The plate bearing the CE mark gives the main characteristics and information for the identification of the scarifier.

- Manufacturer's details
- Machine model
- Serial number
- Year of construction
- Capacity in kW
- Weight in kg

The above information must not be altered or modified in any way.

It is up to the user to keep the plate clean, legible and in good condition.

The position of the CE plate on the machine is shown in the figure below:

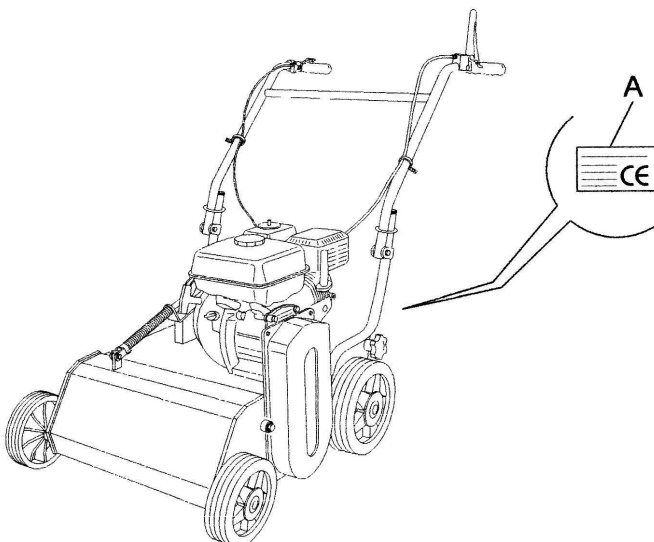

CE DECLARATION OF CONFORMITY

The undersigned manufacturer and depositary of the documentation :

**IBEA s.r.l.
VIA MILANO, 15/17
21049 TRADATE (VA) ITALY**

Hereby declares under its own responsibility that the new machine

type :	SCARIFIER
model :	IB 260
serial number:	from 160001
year of manufacture :	2016
engine power:	3.6 kW

described as follows:

Machine for agricultural use for the cutting of shoots, grass and brushwood

Conforms to the Essential Health and Safety Requisites of Directives 2006/42/CE, 2000/14/CE and 2004/108/CE, .

Applicable standard : EN 13684.

Date
Tradate, 15.06.2016

Ing. Griffini Alberto
(Legal Representative)





IBEA s.r.l. Via Milano, 15/17 - 21049 Tradate (VA)
Tel. 0331-1586940 - Fax 0331-1582268

email ITALY : ibea@ibea.it
email EXPORT : export@ibea.it

www.ibea.it

